

PRE BOARD EXAMINATION (JANUARY – 2019)

CLASS: XII

PHYSICS

Time: 3 hrs.

MAX. MARKS: 70

General Instructions:

- i) All questions are compulsory
- ii) The question paper consists of 27 questions divided into four sections-A,B,C, and D.
- iii) Section A contains 1 to 5 questions of 1 mark each.
Section B contains 6 to 12 questions of 2 marks each.
Section C contains 13 to 24 questions of 3 marks each.
Section D contains 25 to 27 questions of 5 marks each.
- vi) There is no overall choice However an internal choice has been provided in two questions of one mark, two questions of two mark four questions of three mark, and all three questions of five marks weightage .You have to attempt only one of the choices in such questions
- v) Use of log if necessary use of calculators is not allowed.

SECTION –A

1. Current is passing through a conductor of non-uniform area of cross section. At which point the drift velocity will be maximum. (1)

(OR)

Find the angle of dip at a place vertical component of earth's magnetic field is equal to its horizontal.

2. State two factors by which range of transmission of signals by a TV tower can be increased. (1)

(OR)

Plot a graph showing variation of inductive reactance with the change in the frequency of the AC source.

3. Draw block diagram of a receiver. (1)
4. A glass lens of refractive index 1.5 is placed in a liquid. What must be the refractive index of the liquid so that the lens disappears? (1)
5. What happens to the width of the depletion layer of a junction diode when it is (1)
i) forward biased and ii) reverse biased?

SECTION –B

6. State ampere's circuital theorem. By using this obtain an expression for the magnetic field due to an infinitely long straight current carrying conductor. (2)

(OR)

The wavelength of the first line of Lyman series for Hydrogen is identical to that of second line of Balmer series for some hydrogen like ion x. Calculate the energies of the first 4 levels of x.

7. Derive an expression for the force experienced by a current carrying conductor placed in a uniform magnetic field. (2)

(OR)

Two metallic wires of the same material have the same length but cross-sectional areas in the ratio 1:2. They are connected i) in series and ii) in parallel. Compare the drift velocities of electrons in the two wires in cases i) and ii).

8. What is polarization of light? A plane polarized beam of light is passed through a Polaroid. Show graphically the variation of transmitted light intensity with angle of rotation of the Polaroid. (2)

9. The line marked A and B in the given figure, shows a plot of de-Broglie wavelength versus $\frac{1}{\sqrt{V}}$ (2)
 , where 'V' is the accelerating potential for two nuclei H and He.

- a) What does the slope of the lines represent?
 b) Identify, which of the lines corresponds to which nuclei?

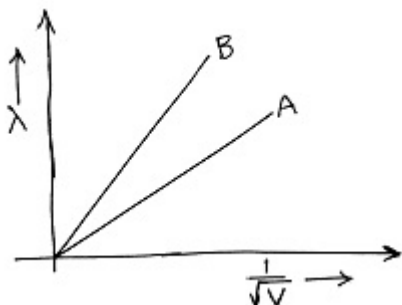

10. State the laws of photoelectric effect. Show graphically the variation of photoelectric current with voltage between electrodes for constant frequency of incident light but for different intensities. (2)

11. Identify the gate obtained in the following combination and write its truth table. (2)

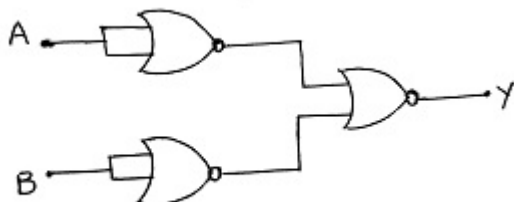

12. A beam of α -particle of velocity $2.1 \times 10^7 \text{ m/s}$ is scattered by a gold foil. Find the distance of closest approach of the α -particle to the gold nucleus. The value of specific charge for α -particle is $4.8 \times 10^7 \text{ C/kg}$. (2)

SECTION -C

13. A uniform electric field of $2 \times 10^3 \text{ N/C}$ is along x-direction. A point charge $3 \mu\text{C}$ of mass $1.2 \times 10^{-4} \text{ kg}$ initially at rest at the origin is released along x-axis. What is the kinetic energy of this charge at $x=4\text{m}$? Also calculate the potential difference at $x=4\text{m}$ and at the origin. (3)

(OR)

Plot a graph showing the variation of photoelectric current with intensity of light.

The work function for the following metals is given as below:

$$Na = 2.75\text{eV} \text{ and } M = 4.175\text{eV}$$

Which of these will give photoelectric emission for a radiation of wavelength 3000 \AA .

14. Calculate the current in each resistance in the electrical circuit as shown in the figure. The internal resistances of the cells are negligible. (3)

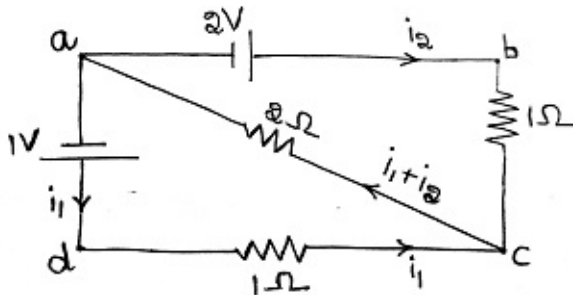

15. Obtain an expression for the magnetic dipole moment of a revolving electron and hence obtain the expression for Bohr magneton. (3)
16. Calculate the time delay between the reception of ground waves for a receiver at a distance of 200km from the transmitter, given that the reflecting ionosphere layer is effectively at a height of 100km . (3)

(OR)

What does the term LOS communication mean? Name the type of waves that are used for this communication.

A transmitting antenna at the top of a tower has a height of 32m and the height of the receiving antenna is 50m . what is the maximum distance between them, for the satisfactory communication in LOS mode?

17. A series LCR circuit with $L = 0.1\text{H}$, $C = 500\text{nF}$, $R = 23\Omega$ is connected to a 230V variable frequency supply. I) What is the source frequency for which current amplitude is maximum. Obtain this maximum value, ii) What is the source frequency for which the average power absorbed by the circuit is maximum, also obtain the value of this maximum power. (3)
18. Box 'A', in the set up shown below, represents an electric device often needed to supply, electric power from the ac mains, to a load. It is known that V_0 is less than V_i . (3)
- Identify the device A and draw its labeled diagram.
 - Explain its principle and theory.

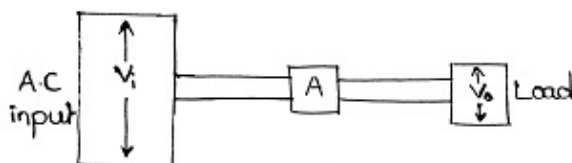

19. State Huygen's principle and derive the law of refraction of light when light goes from a rarer medium to a denser medium using Huygen's principles. (3)

(OR)

- a) What is total internal reflection? Write necessary conditions for it.
 b) Find a relation between critical angle and refractive indices when light is going from medium 1 to 2 (μ_1 less than μ_2).

20. The energy levels of an atom are as shown below. Which of them will result in the emission of a photon of wavelength 275nm? Which transition corresponds to the emission of radiation of maximum wavelength? (3)

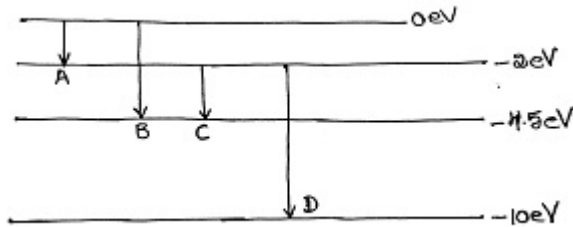

21. State the law of radioactive decay. Establish a relation between half life and disintegration constant (3)

(OR)

- a) Derive the mathematical expression for law of radioactive decay for a sample of a radioactive nucleus.
 b) How is the mean life of a given radioactive nucleus related to the decay constant?

22. A) Can two identical bulbs of same power act as coherent sources of light? (3)

- B) In a young's double slit experiment light of wavelength 6000Å is used and n^{th} bright fringe is obtained at a point P on the screen. Keeping the same setting the source is replaced by a light of wavelength 5000Å and now $(n+1)^{\text{th}}$ bright fringe is obtained at the same place. Calculate the value of n.

23. A) Mention any two properties of electromagnetic waves. (3)

- B) The magnetic field in a plane electromagnetic wave is given as $B_y = 2 \times 10^{-7} \cos(0.5 \times 10^3 t - 1.5 \times 10^{11} x) T$. What are the wavelength and frequency of the wave? Write an expression for the electric field also.

24. A) How does the position of the balance point 'J' changes, when the resistance R_1 is decreased. (3)

- B) Why cannot the balance point be obtained when the emf 'E' is greater than 2V?

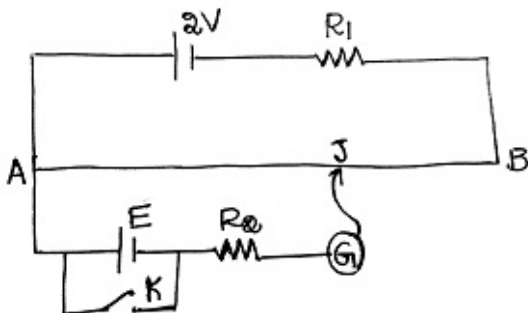

SECTION-D

25. a) Derive the relation between object distance, image distance and radius of curvature for refraction through a convex surface when the object is placed in the rarer medium. (5)

- b) A glass prism of refractive index 1.5 is placed in air. What should be the angle of the prism so that a light beam incident normally on the face AB emerges grazing the adjoining surface AC of the prism?

(OR)

- a) Derive the relation between the angle of incidence, angle of emergence, angle of prism and angle of deviation for refraction of light through a prism.
- b) Draw a graph showing the variation of angle of deviation with angle of incidence.
- c) Why emergent ray is not obtained from the adjoining surface when angle of incidence is very small?
26. a) State Gauss theorem in electrostatics. Obtain an expression for the electric field inside a uniformly charged spherical shell. (5)
- b) Draw equipotential surfaces for an electric dipole.
- c) A balloon carrying charge q is inflated. How the flux through the surface of the balloon will change? Justify.

(OR)

- a) How the capacitance of a given capacitor will change additional charge is given to it.
- b) Derive an expression for the capacitance of a parallel plate capacitor having a dielectric slab of thickness t (t is less than the distance between the plates of the capacitor).
- c) When the plates of a capacitor are displaced away from each other, how the energy of the capacitor will change. The capacitor is disconnected from the cell.
27. a) What is rectifier? With the help of a circuit diagram explain the working of a full wave rectifier using junction diode. (5)
- b) A p-n junction diode is fabricated from a semiconductor with a band gap of 2.8eV . Can it detect a wavelength of 600nm ?

(OR)

- a) Draw a circuit diagram to study the characteristics of a common emitter npn transistor. Draw the input and output characteristic curves. Find the current through the resistance of 2 ohm in the circuit given below.

