

SECOND PREBOARD EXAMINATION (2019-20)

CLASS: XII

Subject: PHYSICS

Date: 01.02.2020

Time allowed: 3Hours

Maximum Marks: 70

General Instructions:

1. All questions are **compulsory**.
2. Please check that this question paper contains 10 printed pages.
3. Please check that there are **37** questions in all.
4. This question paper has four sections: Section A, Section B, Section C and Section D.
5. Section A contains twenty questions of one mark each, Section B contains seven questions of two marks each, Section C contains seven questions of three marks each, and Section D contains three questions of five marks each.
6. There is no overall choice. However, internal choices have been provided in two questions of one mark, two questions of two marks, one question of three marks and three questions of five marks weightage. You have to attempt only one of the choices in such questions.
7. You may use the following values of physical constants wherever necessary.

$$\mu_0 = 4\pi \times 10^{-7} \text{ TmA}^{-1}$$

$$1/4\pi\epsilon_0 = 9 \times 10^9 \text{ Nm}^2\text{C}^{-2}$$

$$c = 3 \times 10^8 \text{ m/s}$$

$$e = 1.6 \times 10^{-19} \text{ C}$$

$$\epsilon_0 = 8.854 \times 10^{-12} \text{ C}^2\text{N}^{-1}\text{m}^{-2}$$

$$h = 6.63 \times 10^{-34} \text{ Js}$$

$$R = 1.03 \times 10^7 \text{ m}^{-1}$$

$$\text{mass of neutron} = 1.67 \times 10^{-27} \text{ kg}$$

$$\text{mass of electron} = 9.1 \times 10^{-31} \text{ kg}$$

$$\text{mass of proton} = 1.673 \times 10^{-27} \text{ kg}$$

Section - A

Directions (Q1-Q10) Select the most appropriate option from those given below each question

1. The SI unit of electric dipole moment is 1
 (a) Cm (b) C/m (c) Vm (d) Am/s
2. Net capacitance of three identical capacitors in series is $1 \mu\text{F}$. What 1
 will be their net capacitance if connected in parallel?
 (a) $1 \mu\text{F}$ (b) $3 \mu\text{F}$ (c) $9 \mu\text{F}$ (d) $12 \mu\text{F}$
3. Drift velocity of the charge carrier per unit electric field is defined as 1
 (a) conductivity (b) mobility (c) relaxation time (d) number density
4. A proton is accelerated through a potential difference V , subjected to a 1
 uniform magnetic field acting normal to the velocity of the proton. If the
 potential difference is doubled, how will the radius of circular path r
 described by the proton in the magnetic field change?
 (a) $r' = \sqrt{2}r$ (b) $r' = r\sqrt{2}$ (c) $r' = 2r$ (d) $r' = r/2$
5. A bar magnet of magnetic moment \vec{m} is placed in a uniform magnetic 1
 field of induction \vec{B} . The torque exerted on it is
 (a) $\vec{m} \cdot \vec{B}$ (b) $-\vec{m} \cdot \vec{B}$ (c) $\vec{m} \times \vec{B}$ (d) $-\vec{m} \times \vec{B}$
6. A $15\mu\text{F}$ capacitor is connected to 220 V, 50 Hz source. Find the 1
 capacitive reactance.
 (a) 212 ohms (b) 2.12 ohms (c) 21.2 ohms (d) 2120 ohms
7. An electron, an alpha-particle, a deuteron and a proton have the same 1
 kinetic energy. Which one of these particles has the shortest de-Broglie
 wavelength?
 (a) electron (b) alpha-particle (c) proton (d) deuteron
8. Identify the part of the electromagnetic spectrum having the 1
 wavelength of 10^{-12}m .
 (a) radio wave (b) microwave (c) Infra-red (d) Gamma rays

9. Write the following radiations in ascending order in respect of their frequencies : X-rays, microwaves, UV-rays and radio waves. 1

- (a) X-rays, microwaves, UV-rays, radio waves
- (b) Radio waves, UV rays, X-rays, microwaves
- (c) X-rays, microwaves, radio waves, UV-rays
- (d) Radio waves, microwaves, UV rays, X-rays

10. You are given following three lenses. Which two lenses will you use as an eyepiece and as an objective to construct an astronomical telescope? 1

Lenses	Power (P)	Aperture (A)
L ₁	3 D	8 cm
L ₂	6 D	1 cm
L ₃	10 D	1 cm

- (a) L₃ as eyepiece and L₁ as objective
- (b) L₂ as eyepiece and L₁ as objective
- (c) L₁ as eyepiece and L₃ as objective
- (d) L₁ as eyepiece and L₂ as objective

Directions (Q11 -Q15) Fill in the blanks with appropriate answer.

11. Mathematical relation for the resistivity of a material in terms of relaxation time, number density, mass and charge of charge carriers in it is_____.

12. The instantaneous current from an a.c. source is $I = 5 \sin (314 t)$ ampere. Average current is _____ and rms value of the current is _____ in one complete cycle. 1

13. The ratio of the intensities at minima to the maxima in the Young's double slit experiment is 9 : 25. The ratio of the widths of the two slits is _____.

14. The factor, which controls the wavelength of light emitted by an LED is _____.

15. The wavelength of radiation emitted when electron in a hydrogen atom jumps from $n = \infty$ to $n = 1$ is _____.

OR

The longest wavelength line in the emission spectrum of hydrogen atom in Balmer series is called _____.

Directions (Q16 -Q20) Answer the following

16. How does the power of a convex lens vary, if the incident red light is replaced by violet light?

17. If a monochromatic source of light is replaced by white light, what change would you observe in the diffraction pattern?

18. C, Si and Ge have same lattice structure. Why is C insulator while Si and Ge are intrinsic semiconductors?

19. State the law that gives the polarity of the induced emf.

20. What is the nuclear radius of Fe^{125} , if that of Al^{27} is 3.6 fermi?

OR

Give the relation between the mean life of a given radioactive nucleus and the decay constant?

Section -B

21. A thin conducting spherical shell of radius R has charge Q spread uniformly over its surface. Using Gauss's law, derive an expression

for the electric field at a point outside the shell.

22. Deduce an expression for the electric potential due to an electric dipole at any point on its axis. Mention one contrasting feature of electric potential of a dipole at a point as compared to that due to a single charge. 2

23. (a) "Increasing the current sensitivity of a galvanometer may not necessarily increase its voltage sensitivity." Justify this statement. 2

(b) A long straight wire carries a steady current I along the positive Y-axis in a coordinate system. A particle of charge $+Q$ is moving with a velocity \vec{v} along the X-axis. In which direction will the particle experience a force?

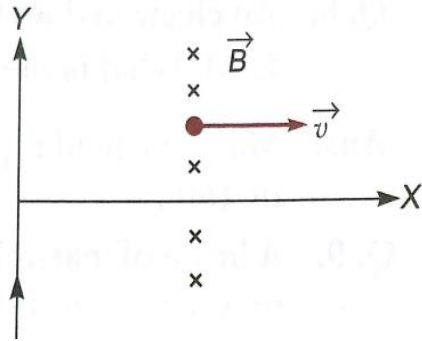

24. Sketch the variation of flux and emf with distance $0 \leq x \leq 2b$ when 2

a conducting rod PQ of resistance R and length l moves freely to and fro between A and C with speed v on a rectangular conductor placed in uniform magnetic field B as shown in the figure. The field extends from $x = 0$ to $x = b$ and is zero for $x > b$.

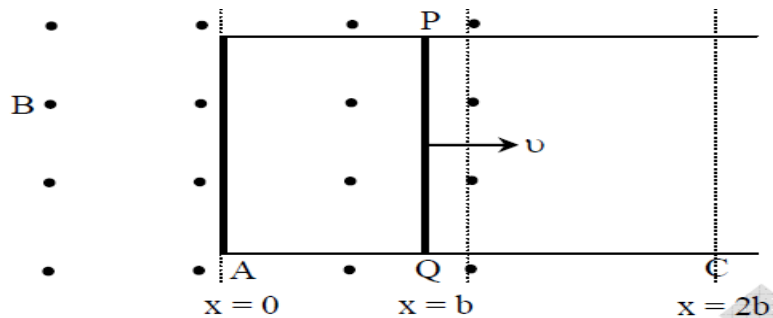

OR

Derive an expression for self-inductance of a long solenoid of length l , cross-sectional area A having N number of turns. 2

25. The oscillating electric field of an electromagnetic wave is given by 2

$$E_y = 30 \sin [2 \times 10^{11}t + 300\pi x] \text{ V/m}$$

- (a) Obtain the value of the wavelength of the electromagnetic wave.
 (b) Write down the expression for the oscillating magnetic field.

26. Define a wave front. Using Huygens principle, draw the refracted wave front, when a plane wave is incident on (i) a concave lens (ii) a thin prism. 2

OR

- (a) Which characteristic of a wave does not change when it refracts from one medium to another? Why? 2
 (b) What is the ratio of the velocity of the wave in the two media of refractive indices μ_1 and μ_2 ?

27. With the help of a suitable diagram, explain the formation of depletion region in a p-n junction. How does its width change when the junction is (i) forward biased, and (ii) reverse biased? 2

Section -C

28. (a) State Kirchoff's rules. 3

(b) In the given circuit, assuming point A to be at zero potential, find the potential at point B.

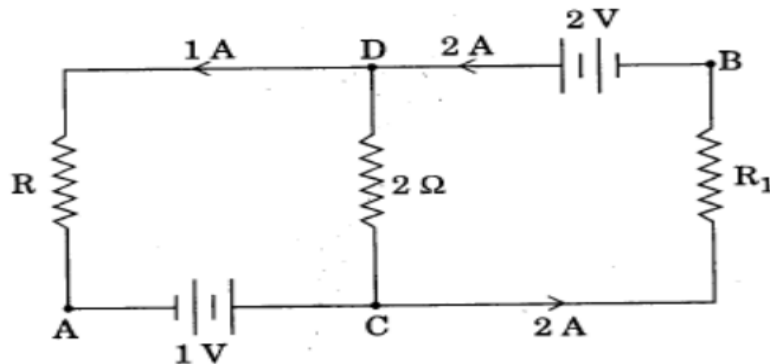

OR

Using Kirchhoff's rules determine the value of currents in the electric circuit given below.

3

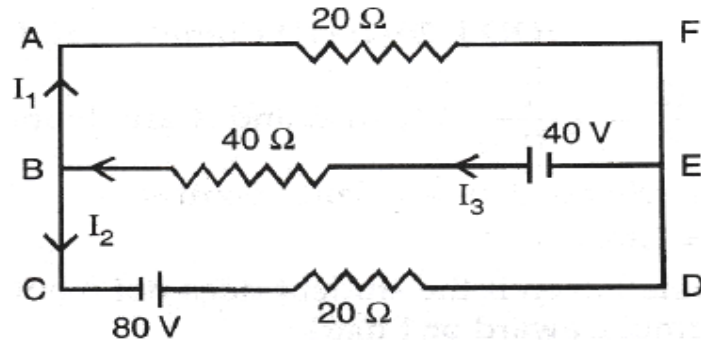

29. State Biot-Savart law. Use it to derive an expression for the magnetic field at the centre of a circular loop of radius R carrying a steady current I . Sketch the magnetic field lines for such a current-carrying loop.

30. A convex lens made up of glass of refractive index 1.5 is placed, in turn, in (i) a medium of refractive index 1.65 (ii) a medium of refractive index 1.33.

(a) Find its focal length when placed in the two media in terms of its focal length in air.

(b) Will it behave as a converging or a diverging lens in the two cases?

31. Sketch the graphs showing the variation of stopping potential with frequency of incident radiations for two photosensitive materials A and B having threshold frequencies $\nu_A > \nu_B$.

(i) In which case is the stopping potential more and why?

(ii) Does the slope of the graph depend on the nature of the material used? Explain.

32. The energy levels of an atom are given below in the diagram.

3

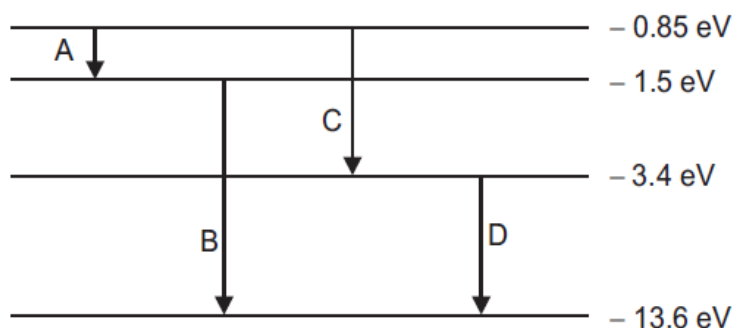

Identify, using necessary calculations, the transition, which corresponds to the emission of a spectral line of wavelength 482 nm.

33. (a) Derive the mathematical expression for the law of radioactive decay of a sample radioactive nuclei. 3
 (b) A radioactive isotope has a half-life of 5 years. How long will it take the activity to reduce to 3.125%?

34. Explain the process of emission of light by a Light Emitting Diode (LED). Which semiconductors are preferred to make LEDs of different colours? Write any two advantages of light emitting diodes over conventional incandescent lamps. 3

Section -D

35. (a) Two heating elements of resistances R_1 and R_2 when operated at a constant supply of voltage V , consume powers P_1 and P_2 respectively. Deduce the expressions for the power of their combination when they are, in turn, connected in (i) series and (ii) parallel across the same voltage supply. 5
 (b) A cell of emf ' E ' and internal resistance ' r ' is connected across a variable resistor ' R '. Plot a graph showing variation of terminal voltage ' V ' of the cell versus the current ' I '. Using the plot, show how the emf of the cell and its internal resistance can be determined.

OR

- (a) A parallel plate capacitor, with each plate of area A and separation d , is charged to a potential difference V . The battery used to charge it is then disconnected. A dielectric slab of thickness d and dielectric constant k is now placed between the plates. What change, if any, will take place in the

- (i) charge on the plates
 - (ii) electric field intensity between the plates
 - (iii) capacitance of the capacitor. Justify your answer in each case.
- (b) Estimate the average drift speed of conduction electrons in a copper wire of cross-sectional area $2.5 \times 10^{-7} \text{ m}^2$ carrying a current of 2.7 A. Assume the number density of conduction electrons to be $9 \times 10^{28} \text{ m}^{-3}$.

36. (a) Explain with the help of a labelled diagram the underlying principle and working of a step-up transformer. Why cannot such a device be used to step-up d.c. voltage? 5
- (b) A magnetising field of 1600 A/m produces a flux of 2.4×10^{-5} weber in a bar of iron of cross-sectional area 0.2 cm^2 . Calculate the permeability and susceptibility of the iron-bar used.

OR

- (a) When an alternating voltage of 220 V is applied across a device X, a current of 0.5 A flows through the circuit and is in phase with the applied voltage. When the same voltage is applied across another device Y, the same current again flows through the circuit but it leads the applied voltage by $\pi/2$ radian. 5
- (i) Name the devices X and Y.
 - (ii) Calculate the current flowing in the circuit when same voltage is applied across the series combination of X and Y.
- (b) Define magnetisation (M) of a magnetic material. How does it change with temperature for a paramagnetic material?

37. (a) In Young's double slit experiment, the two slits are 0.03 cm apart and the screen is placed at a distance of 1.5 m away from the slits. The distance between the central bright fringe and fourth bright fringe is 1 cm. Calculate the wavelength of light used. 5
- (b) Use the mirror equation to show that
- (i) an object placed between f and 2f of a concave mirror produces a real image beyond 2f.

(ii) a convex mirror always produces a virtual image independent of the location of the object.

OR

(a) Define power of a lens. Write its SI unit. Deduce the relation 5

$$\frac{1}{f} = \frac{1}{f_1} + \frac{1}{f_2} \text{ for two thin lenses in contact coaxially.}$$

(b) An unpolarised light is incident on the boundary between two transparent media. State the condition when the reflected wave is totally plane polarised. Draw the diagram and find out the expression for the angle of incidence in this case.